

## Air Purifier CAP 15



## 1. Description CAP 15

### Description:

The air purifier CAP 15 and CAP 30 produces clean and hydrocarbon-free air out of normal compressed air. The Pt/Pd-catalyst convert by catalytical total-oxidation at 370°C all hydrocarbons inclusive methane (CH<sub>4</sub>) into carbondioxyde (CO<sub>2</sub>) and water (H<sub>2</sub>O). Hydrogen (H<sub>2</sub>) and carbonmonoxyde (CO) will be removed quantitatively.

The produced air quality ist constantly free of hydrocarbons and better than sythetic air from gas bottles of class 5.0 (refering to organic components).

On account of the high gas purity, the air purifier CAP 15/30 are used for FID-measuring systems as combustion air and as zero gas.

### Application:

With normal compressed air (2-8 bar, oilfree) the HC content become less than 50 ppb.

The air purifier can make clean air for up to 2-4 FID-Systems in dependance of the model.

The typical amortisation period of the air purifier is less then one year.

The air purifier can used as high purified Air generator down to measuring ranges from 0-10ppm or as combined combustion air and zero gas generator instead of gas bottles.

## 2. Technical Data

### Modell CAP 15

<b>Flow rates:</b>	<b>2,5 l/min</b>
Mains Connection:	230V/50Hz
Ambient-temperature:	0-45°C
Gas connections:	¼" NPT
Start up time:	ca. 30Min
Capacity:	max. 110 Watt
Converter temperature:	370°C – 380°C
Display:	Digital display
Pressure:	2 bis 8 bar g
THC-content:	< 0,1 ppm
Efficiency:	> 99,0 % for Methane > 99,5 % for C <sub>3</sub> H <sub>8</sub> > 99,9 % for Ethylen
Casing:	(B x H x T) 450 x 137 x 260 mm
Weight:	ca. 5,8 kg

## Modell CAP 30

<b>Flow rates:</b>	<b>5,0 l/min</b>
Mains Connection:	230V/50Hz
Ambient-temperature:	0-45°C
Gas connections:	¼" NPT
Start up time:	ca. 30Min
Capacity:	max. 110 Watt
Converter temperature:	370°C – 380°C
Display:	Digital display
Pressure:	2 bis 8 bar g
THC-content:	< 0,1 ppm
Efficiency:	> 99,0 % for Methane > 99,5 % for C <sub>3</sub> H <sub>8</sub> > 99,9 % for Ethylen
Casing:	(B x H x T) 450 x 137 x 260 mm
Weight:	ca. 7,5 kg

### 3. Design / Flow diagram

The air purifier CAP 15 purges compressed air by means of filtration, adsorption and catalytical combustion. At first, the prefilter (F1) removes all particles and aerosol content at 99,99% from the compressed air flow. The indication of the current operating parameters (flow rate and pressure) takes place at the purge meter (FI) (with needle valve for flow rate restriction) and at the manometer (PI). In the electrical heated converter (C1) the gaseous hydrocarbons (HC) are converted by total-oxidation at 360-390°C into carbondioxide (CO<sub>2</sub>) and water (H<sub>2</sub>O). The converter temperature is automatically controlled to be constant at all operating conditions and is indicated on a digital display (TIC). An air cooler (W2) cools down the hot gas to room temperature. The last content of hard cracking substances (FCKW, CKW, SKW) is reduced in the following adsorption filter (F2) (standard adsorbens is an IAC 400) down to a few ppb. A fine dust filter (F3) of natural, porous PTFE (2µm) at the outlet of the air purifier protect the following analyzers. All filters are assembled on the back accessibly and in such a way, facilitate ist maintenance.

#### Flow chart CAP 15

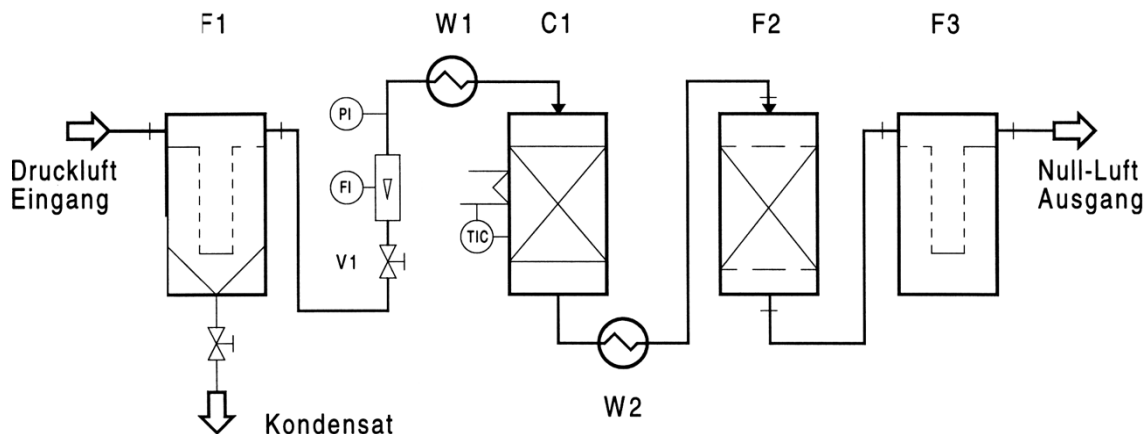

F1	Prefilter	V1	Flow restrictor FR
W1	Pre heating	FI	Purge meter
C1	Converter ( Pt/Pd-Cat)	PI	Manometer
W2	Air cooler with fan	TIC	T-regulator with display for Converter heating
F2	Adsorption-filter (actice coal)		
F3	Dust filter		